

CONCEPT STORE FIXTURES SHELVING & ACCESSORIES GUIDE



SUPERIOR PARTS

FOR ALL LEADING MANUFACTURERS INCLUDING:
HUSSMANN, HILL PHOENIX, KYSOR-WARREN AND TYLER

- 20 GAUGE GALVANIZED METAL
- STRONGER
- MORE DURABLE
- STANDS THE TEST OF TIME

**THE
AFTERMARKET
SPECIALIST**



TWO WAYS TO ORDER

PARTS & ACCESSORIES

THROUGH OUR ONLINE PARTS CATALOGUE

- 1** Identify the parts you want quoted: Gather the model and serial number and have a tape measure on-hand in case there are any measurements needed. Always take pictures of the product you are looking to source.
- 2** Log onto the CSF Online Parts Catalogue at www.conceptfixtures.com
- 3** Build a quote: find the part(s) you want and add them to your cart.
- 4** Submit an order: Either pay online or submit a Purchase Order with your Order.
- 5** Receive your shipment: And make your Store Manager smile.

CONTACT one of our experienced customer service representatives to help you find what you need.



BY PHONE OR EMAIL

- 1** Identify the parts you want quoted: Gather the model and serial number and have a tape measure on-hand in case there are any measurements needed. Always take pictures of the product you are looking to source.
- 2** Call the CSF Customer Center at: 1-844-582-3017 or quote@conceptfixtures.com

Request a Quote: provide the information you gathered above to your Customer Service Rep and they can email you a quote
- 3**
- 4** Submit an Order: Send in a Purchase Order to your Customer Service Rep and they will process your Order and provide you a lead-time
- 5** Receive your shipment: And make your Store Manager smile.

REPLACEMENT MULTIDECK SHELVES - UNLIT

**WE PROVIDE QUALITY PARTS AND ACCESSORIES
TO GIVE NEW LIFE AT VERY COMPETITIVE PRICES.**

INFO@CONCEPTFIXTURES.COM
TOLL FREE: 1-844-582-3017
OFFICE: 450-582-3017
CONCEPTFIXTURES.COM

SHELF SPECIFICATIONS:

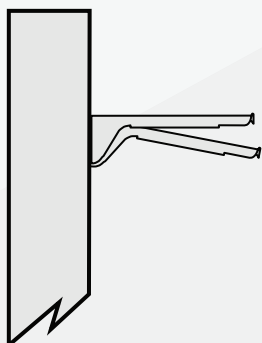

TILT OPTIONS:
0° and 10°

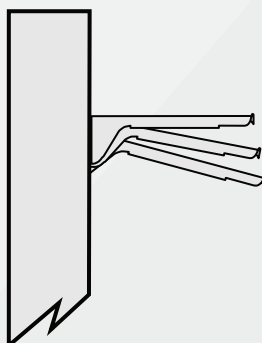

TILT OPTIONS:
0°, 10°
and 15°

Multi-deck shelves are manufactured as a single assembly with shelf deck and brackets included.

Black shelves include black PTM
White shelves include anodized aluminum PTM

FINISHES: Gloss Black, Gloss White, Stainless or Custom Color



LENGTHS: 36" or 48"

DEPTHS: 12" to 24" in 2" Increments (Front to Back)

TILT POSITIONS: 2 and 3 positions (0°, 10°, 15° Tilt Options)

36" LENGTHS

Depths	Hussman	Hill Phoenix	Kysor-Warren	Tyler
12 x 36	HUU-SHF003	HPU-SHF003	KWU-SHF042	TYU-SHF002
14 x 36	HUU-SHF006	HPU-SHF006	KWU-SHF032	TYU-SHF036
16 x 36	HUU-SHF010	HPU-SHF010	KWU-SHF004	TYU-SHF007
18 x 36	HUU-SHF014	HPU-SHF013	KWU-SHF006	TYU-SHF009
20 x 36	HUU-SHF018	HPU-SHF017	KWU-SHF008	TYU-SHF012
22 x 36	HUU-SHF025	HPU-SHF020	KWU-SHF014	TYU-SHF015
24 x 36	HUU-SHF027	HPU-SHF033	KWU-SHF047	TYU-SHF043

48" LENGTHS

Depths	Hussman	Hill Phoenix	Kysor-Warren	Tyler
12 x 48	HUU-SHF005	HPU-SHF004	KWU-SHF002	TYU-SHF003
14 x 48	HUU-SHF007	HPU-SHF007	KWU-SHF003	TYU-SHF04
16 x 48	HUU-SHF004	HPU-SHF011	KWU-SHF005	TYU-SHF008
18 x 48	HUU-SHF015	HPU-SHF014	KWU-SHF007	TYU-SHF010
20 x 48	HUU-SHF020	HPU-SHF018	KWU-SHF009	TYU-SHF013
22 x 48	HUU-SHF026	HPU-SHF021	KWU-SHF012	TYU-SHF016
24 x 48	HUU-SHF029	HPU-SHF022	KWU-SHF022	TYU-SHF018



**PLEASE PROVIDE
WHEN PLACING A CSF SHELF ORDER:**

- Manufacturer, Model and Serial Number
- Shelf width and depth / tilt positions required
- Product stop type and size if needed

LED LIGHTING FOR MULTIDECK SHELVES - UNLIT

LED LIGHTING

SPECIFICATIONS:



Easy installation with Kysor-warren, Hill Phoenix, Hussmann, Tyler and Other Cases

Reduce Energy Usage by 80% compared to T8 alternative

All lights use industrial-strength magnets to mount onto the bottom of the shelf

50,000 ESTIMATED LIFETIME RATING; 5-year warranty on all LED Fixtures and Drivers

LEDs emit less heat into the display case than fluorescents. This helps reduce the rise in internal product temperatures. Which maintains freshness and appearance.

(k)Temperature	36"	48"
3000K	LED002	LED001
3500K	LED004	LED003
4000K	LED006	LED005
Driver		LED-SOURCE04

PLEXIGLASS PRODUCT STOPS

SPECIFICATIONS:



All products are 0.1888" in depth.

Fits in OEM shelf that accepts product stops.

Height	36"	48"
2"	PLX087	PLX046
2.5"	PLX023	PLX088
3"	PLX003	PLX002
4"	PLX059	PLX001

WIRE PRODUCT STOP

SPECIFICATIONS:









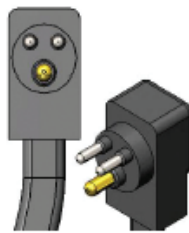
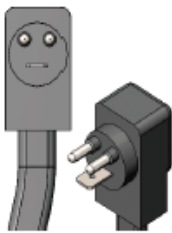
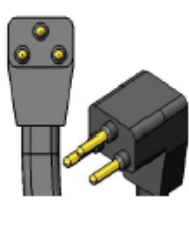
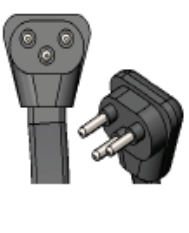
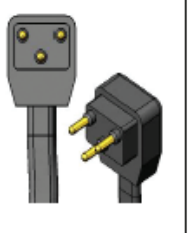

Height	Hussman		Hill Phoenix		Kysor-Warren	
	36"	48"	36"	48"	36"	48"
2"		HU1917				
2.5"	HU433	HU432	HP456	HP394	KW668	KW193
3"	HU1970	HU1969	HP1724	HP1589	KW951	KW952
4"		HU435				

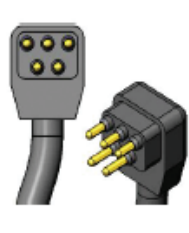
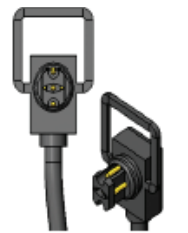
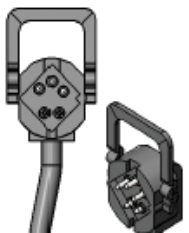
PLUG WORK WITH T8 AND LED LIGHTING OPTIONS

**WE PROVIDE QUALITY PARTS AND ACCESSORIES
TO GIVE NEW LIFE AT VERY COMPETITIVE PRICES.**

INFO@CONCEPTFIXTURES.COM
TOLL FREE: 1-844-582-3017
OFFICE: 450-582-3017
CONCEPTFIXTURES.COM

SPECIFICATIONS:

<p>DEP5-100</p> 	<p>DEP5-225</p> 	<p>DEP5-320</p> 	<p>DEP5-335</p> 	
<p>DEP5-300</p> 	<p>DEP5-340</p> 	<p>DEP5-500</p> 	<p>DEP5-520</p> 	<p>DEP5-533</p> 
<p>DEP5-540</p> 	<p>Hill Phoenix DEP6-100</p> 	<p>Hussmann DEP6-200</p> 	<p>Sanyo/Panasonic DEP6-300</p> 	
<p>Kysor Warren/Heatcraft DEP6-400</p> 	<p>LED DEP7-100</p> 	<p>LED DEP7-200</p> 	<p>LED DEP7-LED</p> 	

A HELPFUL HINT WHEN PLACING A CSF SHELF ORDER:

- Take a picture of the face of the plug and send it to your Sales Rep. A CSF Part Specialist will determine the correct plug for you.

REPLACEMENT T8 LIT - MULTIDECK SHELVES

T8 LIGHTING - MULTIDECK

SPECIFICATIONS:

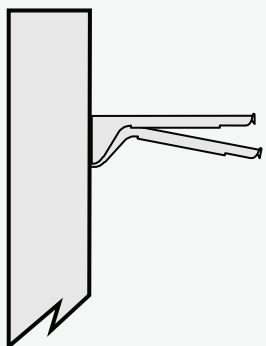

TILT OPTIONS:
0° and 10°

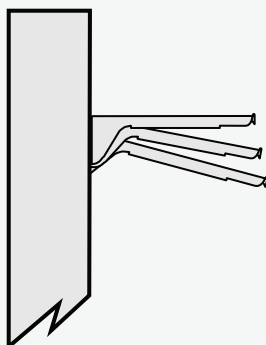

TILT OPTIONS:
0°, 10°
and 15°

Standard bracket, black shelves include black PTM
White shelves include anodized aluminum PTM with slot for plexiproduct stop

FINISHES: Gloss Black, Gloss White, Stainless or Custom Color



LENGTHS: 36" or 48"

DEPTHS: 12" to 24" in 2" Increments (Front to Back)

TILT POSITIONS: 2 and 3 positions (0°, 10°, 15° Tilt Options)

Heavy duty available on 24" shelves and upon request
additional charges apply.

36" LENGTHS - T8 LIT

Depths	Hussman	Hill Phoenix	Kysor-Warren	Tyler
12 x 36	HUL-SHF003	HPL-SHF003	KWL-SHF042	TYL-SHF002
14 x 36	HUL-SHF006	HPL-SHF006	KWL-SHF032	TYL-SHF036
16 x 36	HUL-SHF010	HPL-SHF010	KWL-SHF004	TYL-SHF007
18 x 36	HUL-SHF014	HPL-SHF013	KWL-SHF006	TYL-SHF009
20 x 36	HUL-SHF018	HPL-SHF017	KWL-SHF008	TYL-SHF012
22 x 36	HUL-SHF025	HPL-SHF020	KWL-SHF014	TYL-SHF015
24 x 36	HUL-SHF027	HPL-SHF033	KWL-SHF047	TYL-SHF043

48" LENGTHS - T8 LIT

Depths	Hussman	Hill Phoenix	Kysor-Warren	Tyler
12 x 48	HUL-SHF005	HPL-SHF004	KWL-SHF002	TYL-SH003
14 x 48	HUL-SHF007	HPL-SHF007	KWL-SHF003	TYL-SH004
16 x 48	HUL-SHF012	HPL-SHF011	KWL-SHF005	TYL-SH008
18 x 48	HUL-SHF015	HPL-SHF014	KWL-SHF007	TYL-SH010
20 x 48	HUL-SHF020	HPL-SHF018	KWL-SHF009	TYL-SH013
22 x 48	HUL-SHF026	HPL-SHF021	KWL-SHF012	TYL-SH016
24 x 48	HUL-SHF029	HPL-SHF022	KWL-SHF022	TYL-SH018

**PLEASE PROVIDE
WHEN PLACING A CSF SHELF ORDER:**

- Manufacturer, Model and Serial Number
- Shelf width and depth / tilt positions required
- Product stop type and size if needed

REPLACEMENT REACH-IN SHELVES

**WE PROVIDE QUALITY PARTS AND ACCESSORIES
TO GIVE NEW LIFE AT VERY COMPETITIVE PRICES.**

INFO@CONCEPTFIXTURES.COM
TOLL FREE: 1-844-582-3017
OFFICE: 450-582-3017
CONCEPTFIXTURES.COM

REACH-IN SHELVES

SHELF SPECIFICATIONS:

30" WIDTH

Depths	Hussman	Hill Phoenix	Kysor-Warren	Tyler
18 x 30	HUU-SHF030	HPU-SHF023	KWU-SHF056	TYU-SHF035
20 x 30	HUU-SHF033	HPU-SHF024	KWU-SHF015	TYU-SHF033
21 x 30	HUU-SHF123	HPU-SHF076	KWU-SHF016	TYU-SHF047
22 x 30	HUU-SHF035	HPU-SHF019	KWU-SHF017	TYU-SHF020
24 x 30	HUU-SHF036	HPU-SHF025	KWU-SHF018	TYU-SHF029
27 x 30	HUU-SHF124	HPU-SHF026	KWU-SHF010	TYU-SHF031

FINISHES: Gloss Black, Gloss White, Stainless or Custom Color



LENGTHS: 30" wide

DEPTHS: Various depths between 18" and 27"

ZERO ZONE

Depths	RID - 30"W	RID - 31"W	RMZ - 30"W	RMZ - 31"W	RVZC - 30"W
18 x 30			ZZU-SHF016		
20 x 30			ZZU-SHF012		
22 x 30	ZZU-SHF001	ZZU-SHF002	ZZU-SHF004	ZZU-SHF-006	ZZU-SHF-019
24 x 30			ZZU-SHF018		ZZU-SHF-020



**PLEASE PROVIDE
WHEN PLACING A CSF SHELF ORDER:**

- Manufacturer, Model and Serial Number
- Shelf width and depth
- Product stop type and size if needed

ANTHONY FLAT SHELVES

REPLACEMENT SHELVES

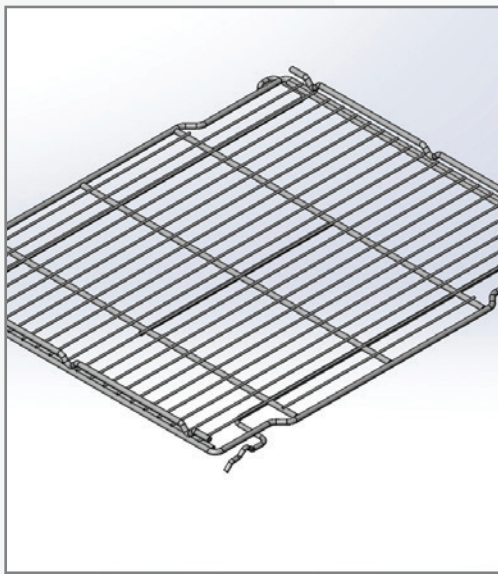

SHELF SPECIFICATIONS:

FINISHES: Gloss Black, Gloss White, Stainless or Custom Color



WIDTHS: 24" to 30" in 2" increments wide

DEPTHS: 24", 27", 36" or 43"

Depths	24"	27"	36"	43"
24"	CF457	CF458	CF459	CF460
26"	CF461	CF462	CF463	CF464
28"	CF465	CF466	CF467	CF468
30"	CF469	CF470	CF471	CF472

WIRE DIVIDERS & POST LOCATORS



SPECIFICATIONS:

Accessories	24"W	27"W	36"W	36"W
Wire Divider	CF527	CF524	CF528	CF529
Post Locators	CF599-24D	CF599-27D	CF599-36D	CF599-43D

Lorem ipsum Lorem ipsum dolor sit amet, consectetur adipiscing elit, sed diam nonummy nibh euismod tincidunt.

POSTS & POST CLIPS



SPECIFICATIONS:

Accessories	
CF600 - 81.5H	POST 81" WITH LEVELING LEG, GALV
CF600-84.5H	POST 85" WITH LEVELING, GALV
CF733	POST CLIP

Lorem ipsum Lorem ipsum dolor sit amet, consectetur adipiscing elit, sed diam nonummy nibh euismod tincidunt.

**PLEASE PROVIDE
WHEN PLACING A CSF SHELF ORDER:**

- Manufacturer, Model and Serial Number
- Shelf width and depth
- Product stop type and size if needed







ANTHONY DOOR REPLACEMENT PARTS

**WE PROVIDE QUALITY PARTS AND ACCESSORIES
TO GIVE NEW LIFE AT VERY COMPETITIVE PRICES.**

INFO@CONCEPTFIXTURES.COM
TOLL FREE: 1-844-582-3017
OFFICE: 450-582-3017
CONCEPTFIXTURES.COM

FULL MASTER BUMPER

SHELF SPECIFICATIONS:

	Part Number	CSF Part Number	Description	Color
	140-10002-0101	ED005B	Hinged Pin	Black
	140-10002-0102	ED005S	Hinged Pin	Silver
	140-10002-0201	ED006B	Hinged Pin with 3 wire leads	Black
	140-10002-0202	ED006S	Hinged Pin with 3 wire leads	Silver
	140-10001-0100	ED008S	Torque Rod	Silver
	140-10003-0101	ED007B	Torque master	Black
	140-10003-0102	ED007S	Torque master	Silver
	170-10001-0101	ED009B	Arch Handle	Black
	170-10001-0102	ED009S	Arch Handle	Silver
	141-1004-0101	DOOR29	Hold Open Arm Assembly Kit	Black
	140-10004-0101	DOOR13	Hold Open	Black

PLASTIC BUMPERS AND KICKPLATES

FULL MASTER BUMPER

SHELF SPECIFICATIONS:

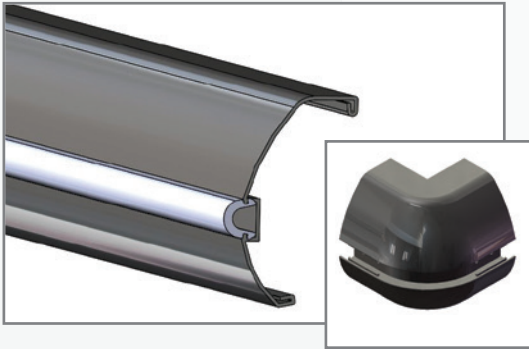

Hill Phoenix	
HP021	HP MASTER BUMPER 144" CUT
HP020	HP 1" BUMPER NOSE, PER FOOT
HP552	HP MASTER BUMPER CORNER

3/4 MASTER BUMPER

SPECIFICATIONS:



Hill Phoenix	
HP022	HP MASTER BUMPER 144" CUT
HP020	HP 1" BUMPER NOSE, PER FOOT
HP598	HP MASTER BUMPER CORNER, 3/4"

HALF MASTER BUMPER

SPECIFICATIONS:

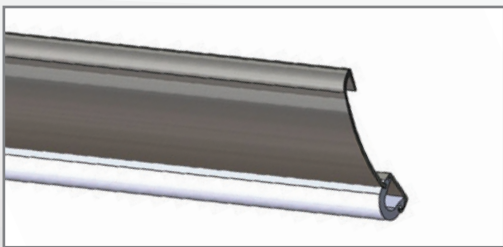

Hill Phoenix	
HP023	HP MASTER BUMPER 144" HALF
HP020	HP 1" BUMPER NOSE, PER FOOT
HP312	HP MASTER BUMPER CORNER, HALF

PLASTIC KICKPLATES

SPECIFICATIONS:

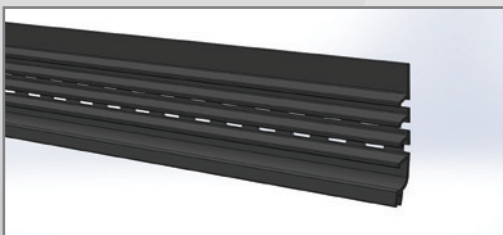

Hill Phoenix	
HP076	HP VENTED PLASTIC KICKPLATE 154"

HUSSMANN REPLACEMENT DOOR PARTS

**WE PROVIDE QUALITY PARTS AND ACCESSORIES
TO GIVE NEW LIFE AT VERY COMPETITIVE PRICES.**

INFO@CONCEPTFIXTURES.COM
TOLL FREE: 1-844-582-3017
OFFICE: 450-582-3017
CONCEPTFIXTURES.COM

REPLACEMENT GASKETS

SPECIFICATIONS:



Hussman OEM-Exact Replacement Gaskets		
	BLACK	GRAY
HUSSMAN INNOVATOR 30 x 65	CF754 BK	CF756 GRY
HUSSMAN INNOVATOR 30 x 65	CF757 BK	CF758 GRY

GET TO KNOW CONCEPT STORE FIXTURES

For over 25 years CSF has manufactured a full range of cost-effective products to help retailers maintain, upgrade, and extend the life of refrigerated cases. Our 250,000 plus square foot manufacturing facility boasts state-of-the-art equipment allowing us to deliver the latest energy saving and cutting edge products to our customers. CSF is uniquely qualified to deliver a complete service package to help retailers maintain, upgrade, and extend the life of their refrigerated cases.

CUSTOM, RETRO-FIT, RE-SKIN, AND REMODEL

A door manufactured by CSF will lower energy costs, increase food safety, deliver better product integrity, and enhance your customer's shopping experience. We provide store survey, design, manufacturing, and installation. Our knowledgeable staff can show you how easy the process can be. CSF boasts one of the largest product lines in the industry. We are the leading manufacturer of aftermarket parts and accessories in North America and service all brands of cases. Our commitment to quality products, competitive prices, and the fastest industry turn times are what built our reputation as an innovative leader.

OEM REPLACEMENT PARTS

CSF is your one stop for all OEM replacement parts. We have one of the largest inventory of parts in the industry for all manufacturers and pride ourselves on fast turn around. Parts are manufactured using 20 gauge galvanized metal so they will not rust. Every part is food grade, powder coated paint for durability and eye appeal. We offer a national network of quality installation crews to make sure your program goes smoothly. We are the largest aftermarket shelving manufacturer in the United States. Give us a call and let us show you how we can deliver a better product, save you more energy, increase your sales, all while saving you money



**WE PROVIDE QUALITY PARTS AND ACCESSORIES
TO GIVE NEW LIFE AT VERY COMPETITIVE PRICES.**

INFO@CONCEPTFIXTURES.COM
TOLL FREE: 1-844-582-3017
OFFICE: 450-582-3017
CONCEPTFIXTURES.COM

 **QUESTIONS? CALL OUR CUSTOMER CENTER: 1-844-582-3017**

©2019 Concept Store Fixtures, Inc. • 429 Rue des Industries
Repentigny, Quebec Canada, J5Y 4Y8
U.S. & Canada 1-844-582-3017 • www.conceptfixtures.com



WWW.CONCEPTFIXTURES.COM

**THE
AFTERMARKET
SPECIALIST**

